

+23dBm PA and PA Predriver with 37% Efficiency for 2.4GHz FHSS WLAN Applications

Presents design trade-offs and measured performance of MAX2644 and MAX2242 for PA and PA driver in FHSS radios for WLAN applications. Bias and RF layout and matching are modified to improve performance at 2450MHz. +23dBm output power was achieved with -12dBm input power. Supply current is 185mA with 3V applied.

Additional Information: [Wireless Product Line Page](#)
[Quick View Data Sheet for the MAX2242](#)
[Quick View Data Sheet for the MAX2644](#)
[Applications Technical Support](#)

There are many commercially available transceivers optimized for 2.4GHz FHSS (frequency-hopping spread spectrum) applications, such as Bluetooth, HomeRF, and DECT (digital European cordless telephone). The majority of these ICs have limited transmit power and therefore are restricted to transmitting over very short distances. Many PC-card manufacturers seeking to differentiate their product from the competition are adding external PAs (power amplifiers) to extend the transmit range of their product. Bluetooth and HomeRF allow a maximum output power of +20dBm (100mW) at the antenna, whereas 2.4GHz DECT can transmit up to +24dBm (250mW). PAs for these applications are generally required to deliver between +23dBm and +27dBm to overcome an expected 3dB of loss in the RF switch and duplexer, which separate the PA and the antenna (see Figure 1). To prolong battery life, Bluetooth and DECT utilize GFSK (Gaussian frequency-shift keying) modulation and HomeRF uses two- and four-level FSK, which allows the use of saturated PAs, which are more power-efficient than linear power amplifiers.

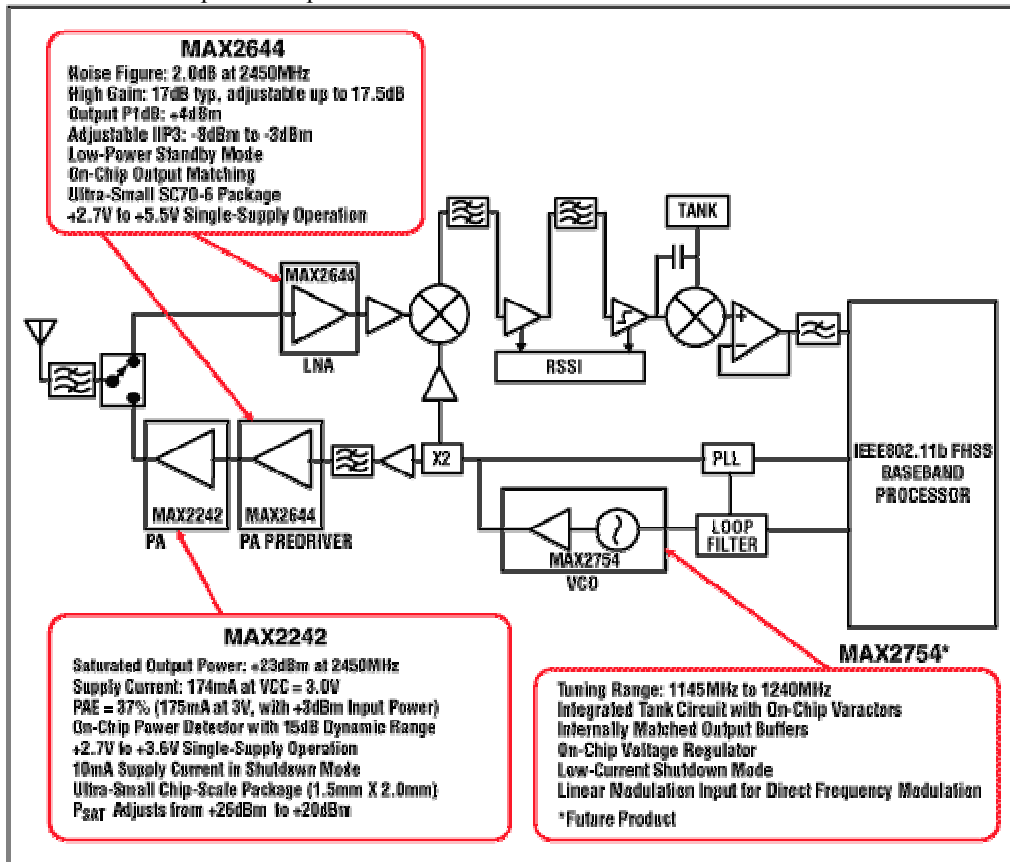

Figure 1. A 2.4GHz FHSS WLAN transceiver for Bluetooth, HomeRF, and DECT

This application note demonstrates the performance of the MAX2242 2.4GHz PA in CSP (chip-scale package) configuration (1.5mm x 2.0mm) with an integrated power detector and 0.5μA supply-current shutdown feature (see Figure 2). Also employed is the MAX2644, a 2.4GHz LNA used here as a PA predriver. The MAX2242 PA was characterized initially for 2.4GHz IEEE802.11b DSSS (direct-sequence spread spectrum) application. For DSSS application, the PA delivers +22.5dBm of linear output power, with -33dBc ACPR performance from a 3.3V supply at a supply-current draw of 310mA. The saturated output power for this application is +26.5dBm, which is perfect as is for 2.4GHz DECT. The MAX2242 uses an external resistor to set the device's bias current, which essentially allows the device's performance to be tailored for a specific application. A design goal of +23dBm saturated output power was targeted for the PA, anticipating approximately 3dB of loss between the PA and the antenna to provide the required +20dBm at the antenna. Because many of the FHSS transceiver ICs available provide only between -7dBm and -13dBm of output power, a PA predriver was required to provide the necessary input power to drive the PA into saturation. The MAX2644 with 17dB of small-signal gain and an output P1dB compression point of +4dBm was a perfect candidate.

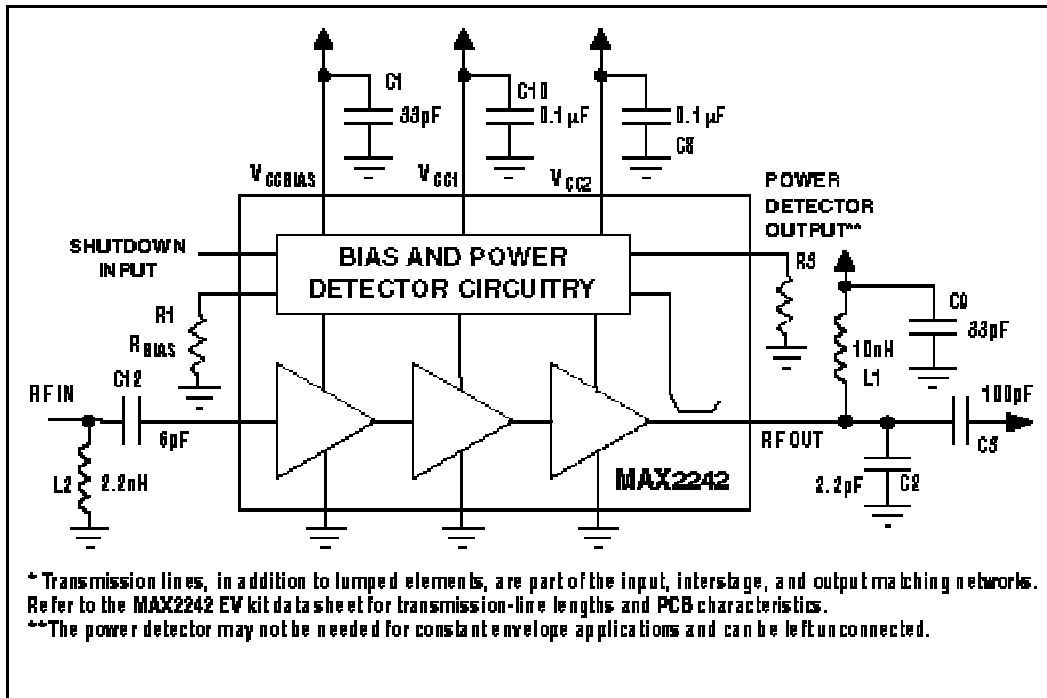

Figure 2. MAX2242 typical application circuit

The performance and circuit changes were made to an existing MAX2242 EV kit. The existing circuit required few changes to achieve the desired performance. The external bias resistor was changed to 91kΩ. A shunt output capacitor, C2, was changed from 1.8pF to 2.2pF, and moved slightly further away from the device output (5.5 notches in the EV kit layout, 230mils from the output pullup inductor). Interstage RF bypass capacitor C8 was moved in (between the pads for C7 and C8, 70mils from pad A2), and C10 was moved out (135mils from pad A4). Moving these capacitors helped to improve interstage gain, which had been backed off to improve the ACPR performance of the device under linear operation. See Figure 3 for component location, and refer to the [MAX2242 EV kit data sheet](#) for board-layout assistance.

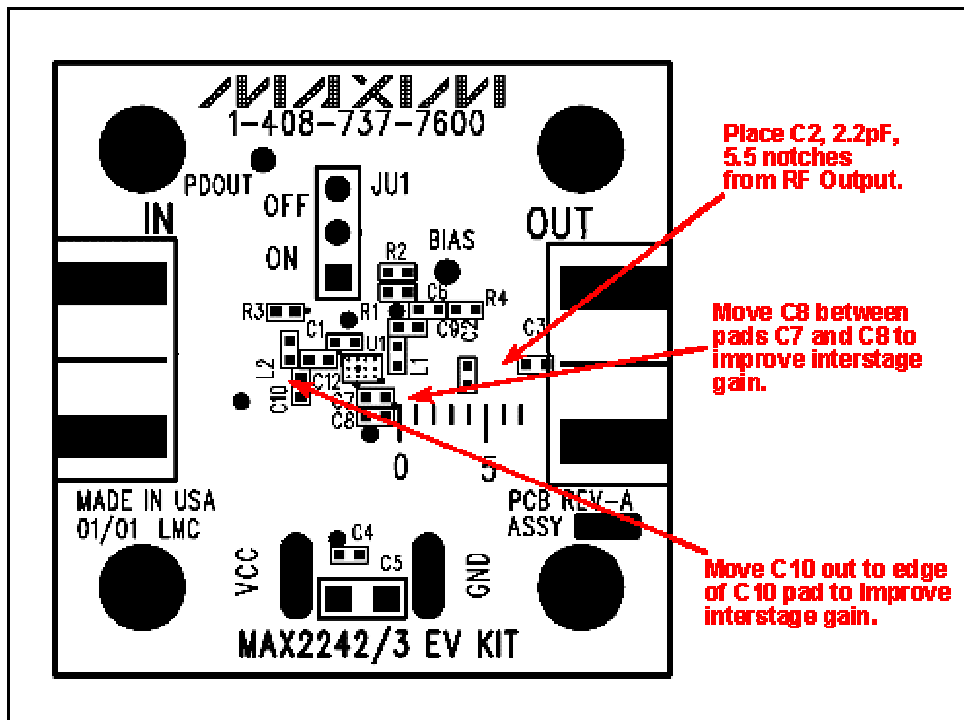

Figure 3. MAX2242 +23dBm component-placement guide

The MAX2242 was tuned for +23dBm of saturated output power, at a supply-current draw of 175mA (37% power-added efficiency, or PAE) from a 3.0V supply voltage at room temperature ($T_A = +25^\circ\text{C}$). Output power, supply current, gain, and PAE were measured versus input power, supply voltage, and frequency (see Figures 4 through 7). An interesting characteristic of the PA is that, when RF power is removed, supply-current draw drops to 29mA, whereas competing PAs remain biased at more than 150mA (see Figure 8). The harmonic content of the PA was also evaluated, with a worst-case spur down 35dB below the carrier.

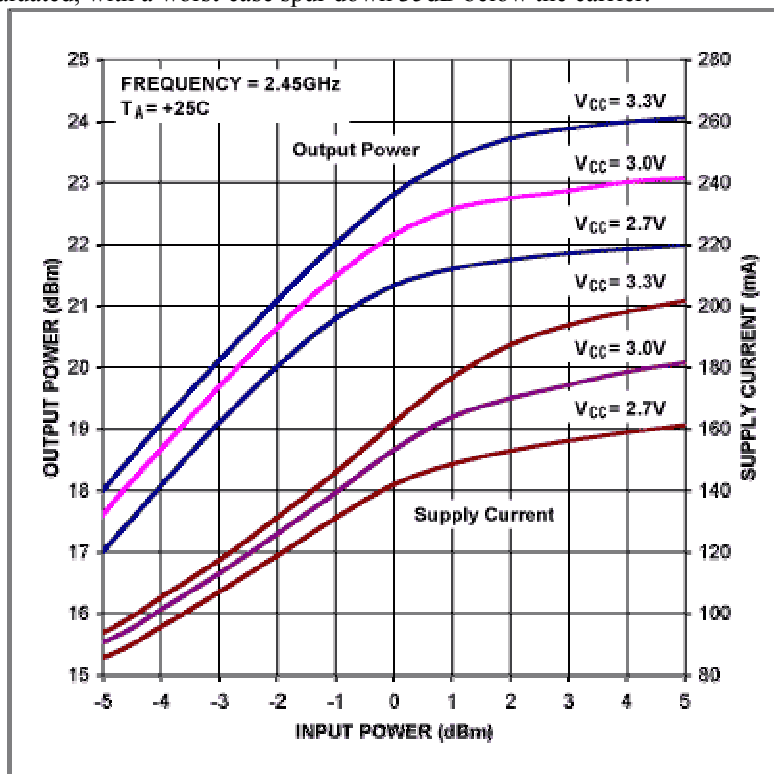

Figure 4. The MAX2242 PA's output power and supply current vs. input power

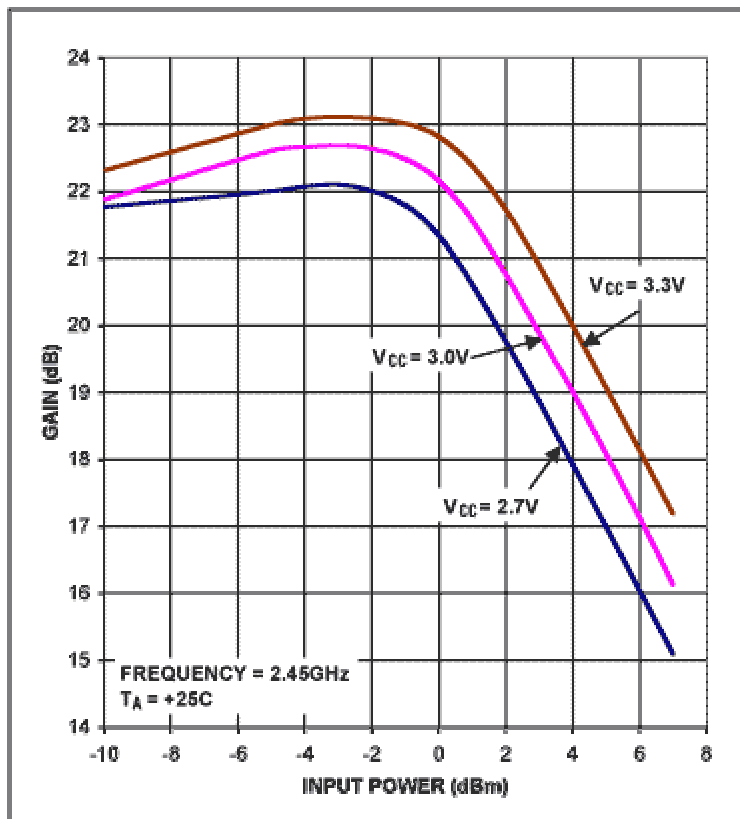

Figure 5. The MAX2242 PA's gain vs. input power

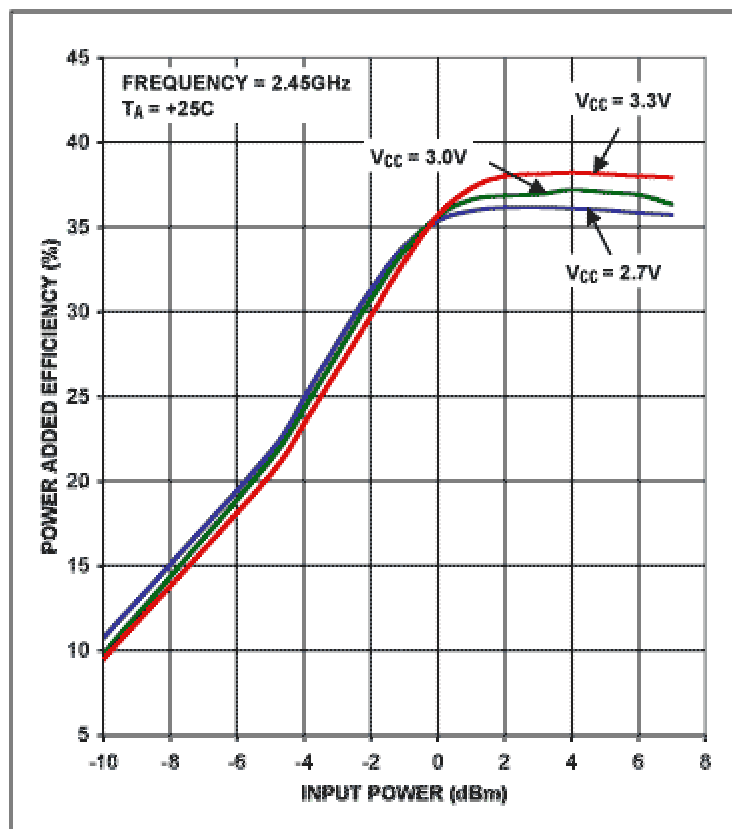

Figure 6. The MAX2242 PA's power-added efficiency (PAE) vs. input power

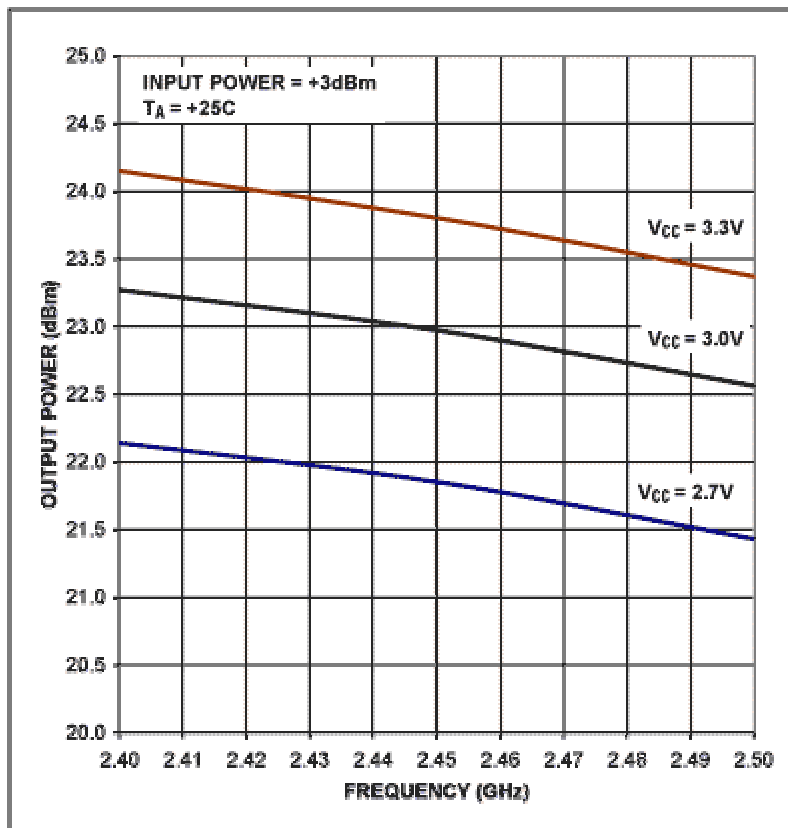

Figure 7. The MAX2242 PA's output power vs. frequency

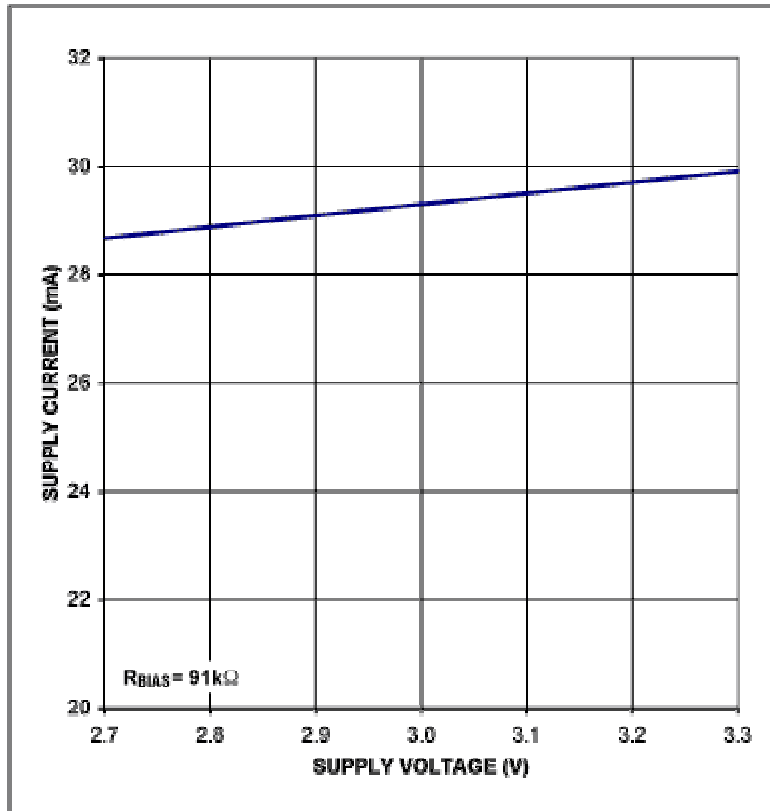

Figure 8. The MAX2242 PA's supply current with no RF power applied

The MAX2644 2.4GHz LNA was selected as a PA predriver because of its +4dBm output P1dB compression point, 17dB of small-signal gain, low 8mA current draw, and integrated output matching network. The MAX2644 EV kit required no modification and was used as is, off the shelf. For this application, output power and supply current for the MAX2644 were measured versus input power and supply voltage (see Figures 9 and 10). When driven with -13dBm to -7dBm of input power, the MAX2644 provides 3dBm to 6dBm of output power at 2.45GHz from a 3V supply.

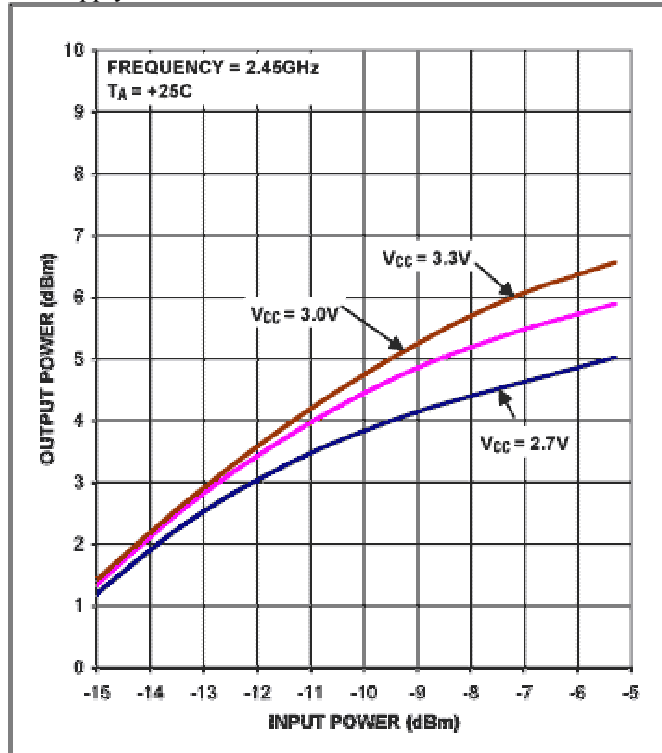

Figure 9. The MAX2644 PA's predriver output power vs. input power

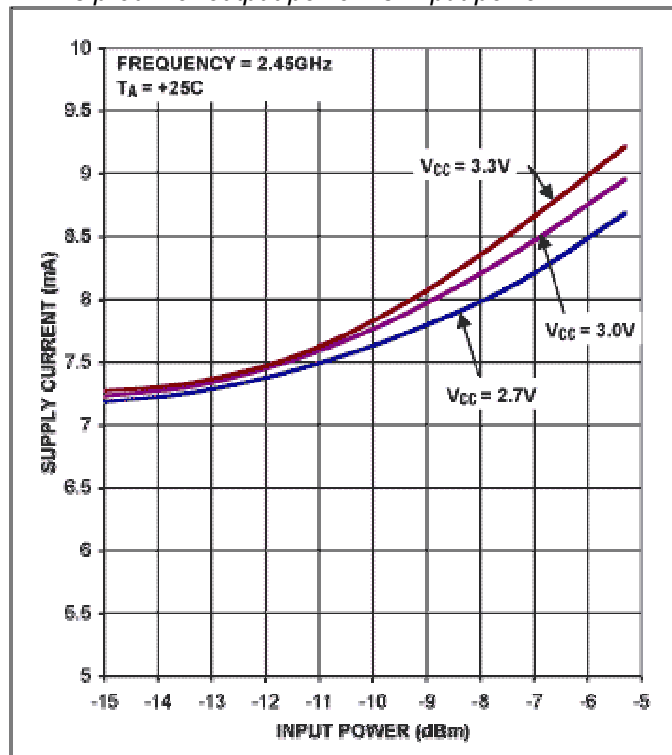

Figure 10. The MAX2644's supply current vs. input power

The cascaded performance of the MAX2644 and the MAX2242 were then measured for the range of output power available for the transmitter IC. The lineup provided +23dBm of output for input powers from -12dBm to -5dBm, dropping to +22.9dBm at -13dBm, the worst-case anticipated input power (see Figure 11). Supply-current draw was approximately 185mA from a 3V supply (see Figure 12). Output power versus frequency remained fairly constant from +23.3dBm at 2.40GHz to +22.8dBm at 2.48GHz (see Figure 13).

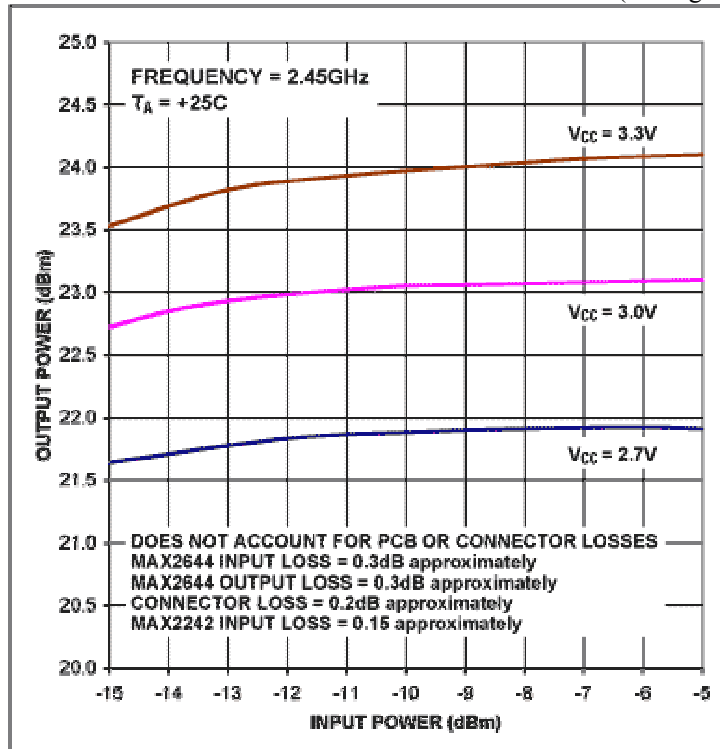

Figure 11. MAX2644 and MAX2242 cascaded performance

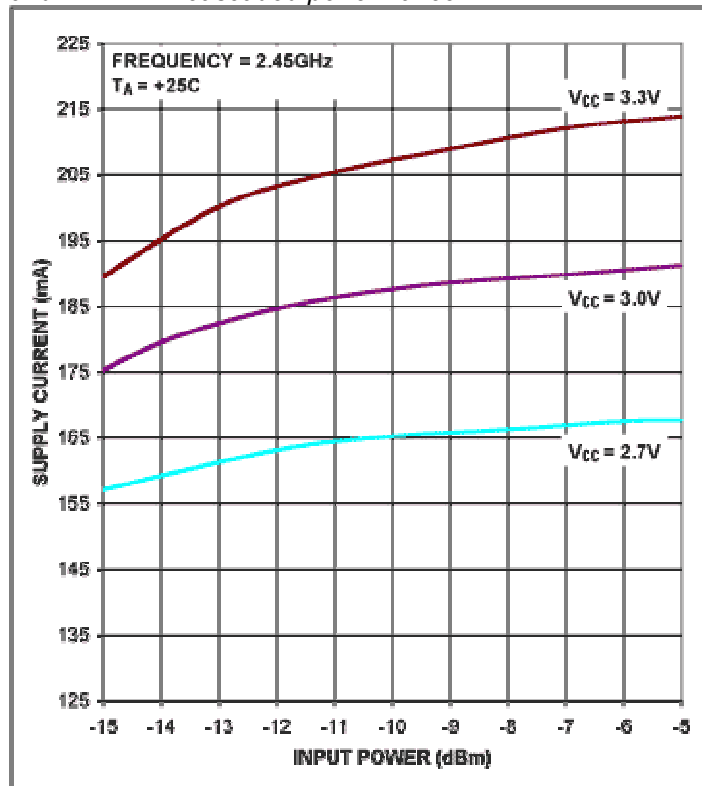

Figure 12. MAX2644 and MAX2242 total supply current vs. input power

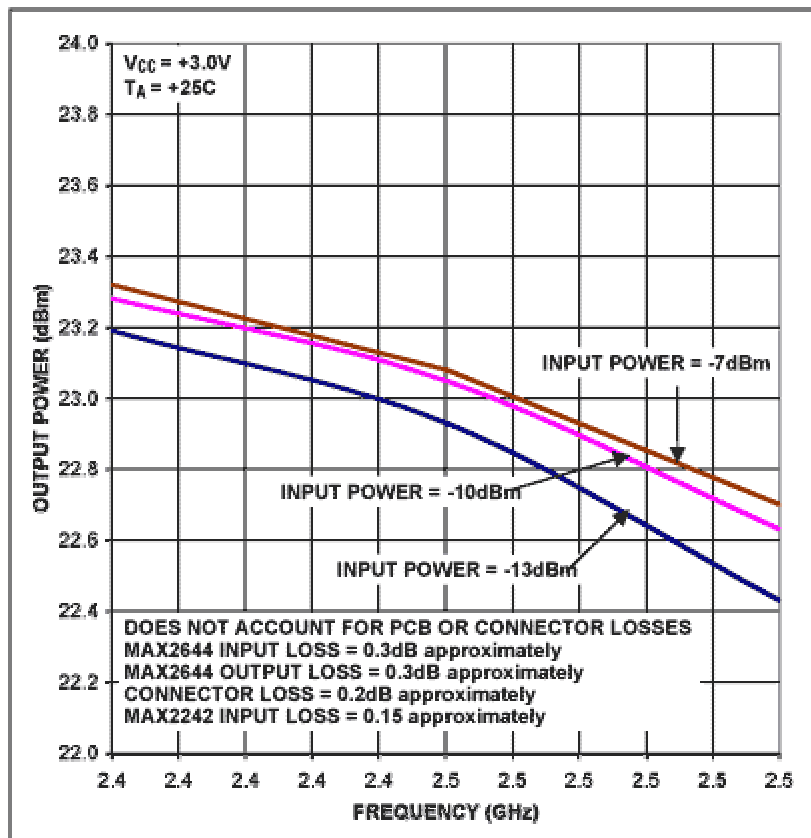

Figure 13. MAX2644 and MAX2242 cascaded output power vs. frequency

The measured performance shows the MAX2644 and MAX2242 to be an excellent choice for the PA and PA driver stages of any low-cost, low-current FHSS radio design requiring a minimum of board space. Selecting the MAX2644 as your receive-path LNA, with 17dB of gain, a 2.0dB noise figure at 2.45GHz, and integrated output matching, can further help to reduce costs and improve the dynamic range of the system.

May 2001

MORE INFORMATION

- MAX2242: [QuickView](#) -- [Full \(PDF\) Data Sheet \(200k\)](#) -- [Free Sample](#)
- MAX2644: [QuickView](#) -- [Full \(PDF\) Data Sheet \(176k\)](#) -- [Free Sample](#)
- MAX2754: [QuickView](#) -- [Full \(PDF\) Data Sheet \(200k\)](#) -- [Free Sample](#)